



ALPHA2 25-40 130

AUTOADAPT

(EEI) -

N)

, Energieeinsparverordnung - EnEV § 14

(3).

ALPHA.

• ALPHA2

<0,8

: 2 .. 110 °C

60 °C

983.2 / ³

TF

110

: VDE,GS,CE

EN-GJL-150

ASTM A48-150B

PES 30%GF

: 0 .. 40 °C

10
G 1 1/2
PN 10
130

-P1: 3 .. 18
50 Hz
1 x 230 V
: 0.04 .. 0.18 A
(IEC 34-5): X4D
(IEC 85): F

(EEI): 0.15
1.88
2
0.004 ³

:
: 0 .. 40 °C
: 10
: G 1 1/2
: PN 10
: 130
-P1: - :
: 3 .. 18
: 50 Hz
: 1 x 230 V
: 0.04 .. 0.18 A
(IEC 34-5): X4D
(IEC 85): F
:
(EEI): 0.15
: 1.88
:
: 2
:
: 0.004 ³

ALPHA2 25-40 130 50

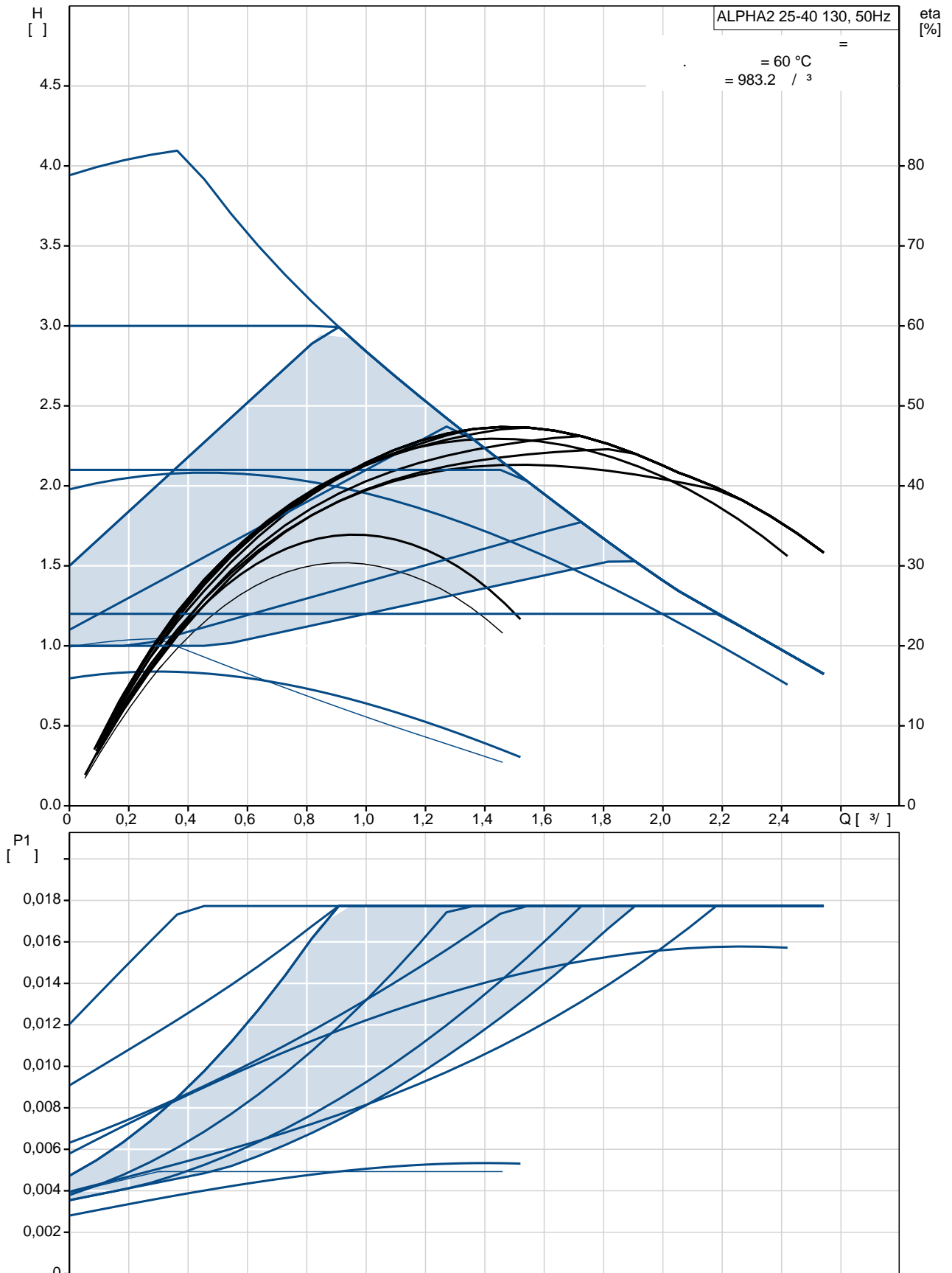

ALPHA2 25-40 130

EAN

TF

40
110
VDE,GS,CE
D

EN-GJL-150
ASTM A48-150B
PES 30%GF

0 .. 40 °C

10
G 1 1/2
PN 10
130

2 .. 110 °C
60 °C
983.2 / ³

..-P1: 3 .. 18
50 Hz
1 x 230 V
0.04 .. 0.18 A
(IEC 34-5): X4D
(IEC 85): F
ELEC

6H

(EEI): 0.15
1.88
2
0.004 ³

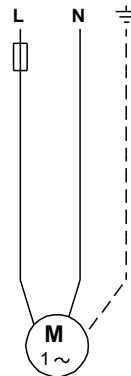
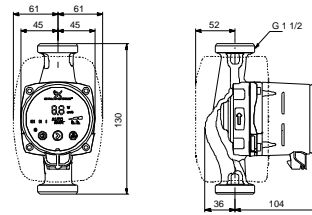
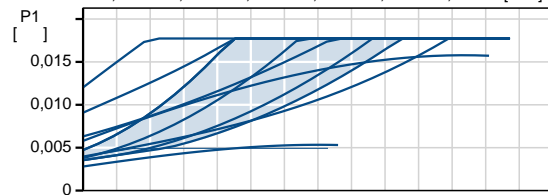
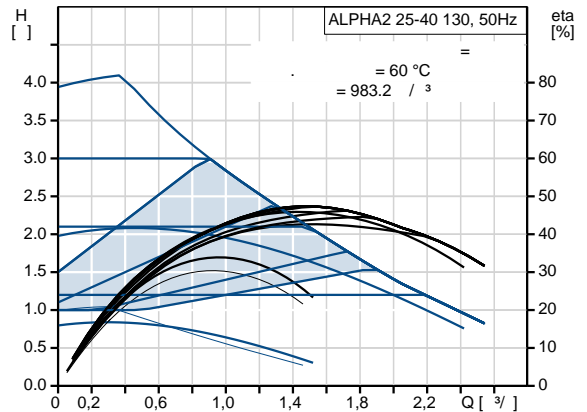

ALPHA2 25-40 130 50

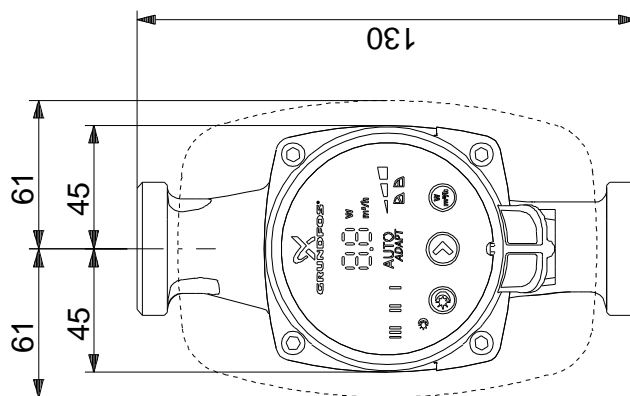
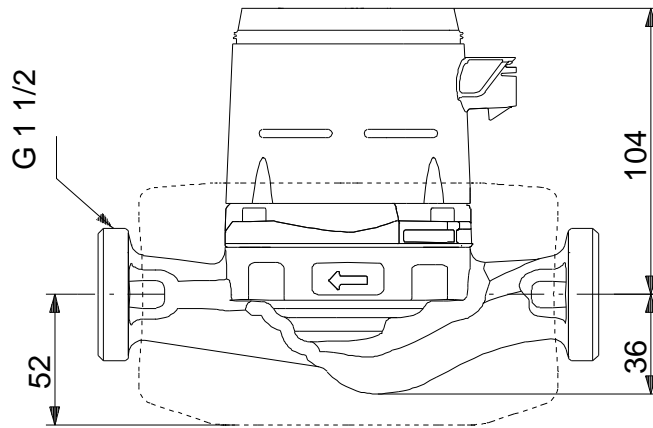

ALPHA2 25-40 130 50

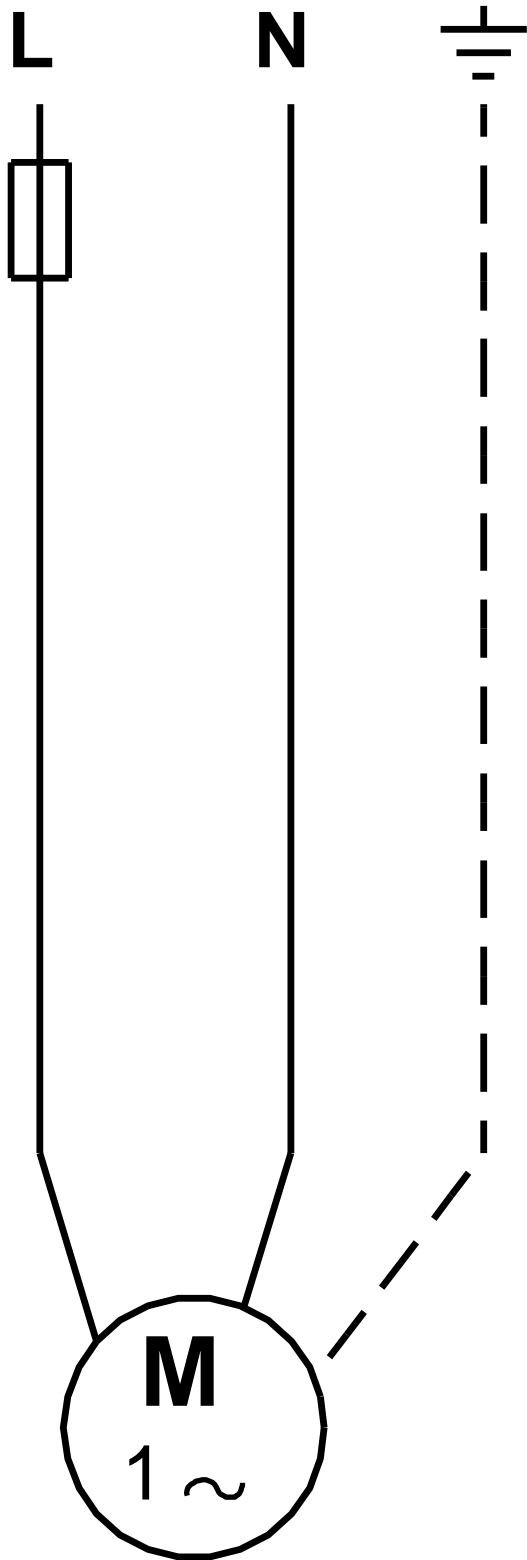

! [], .